

Installation: 12 vdc, Double Acting (Power UP / Power DOWN) Unit

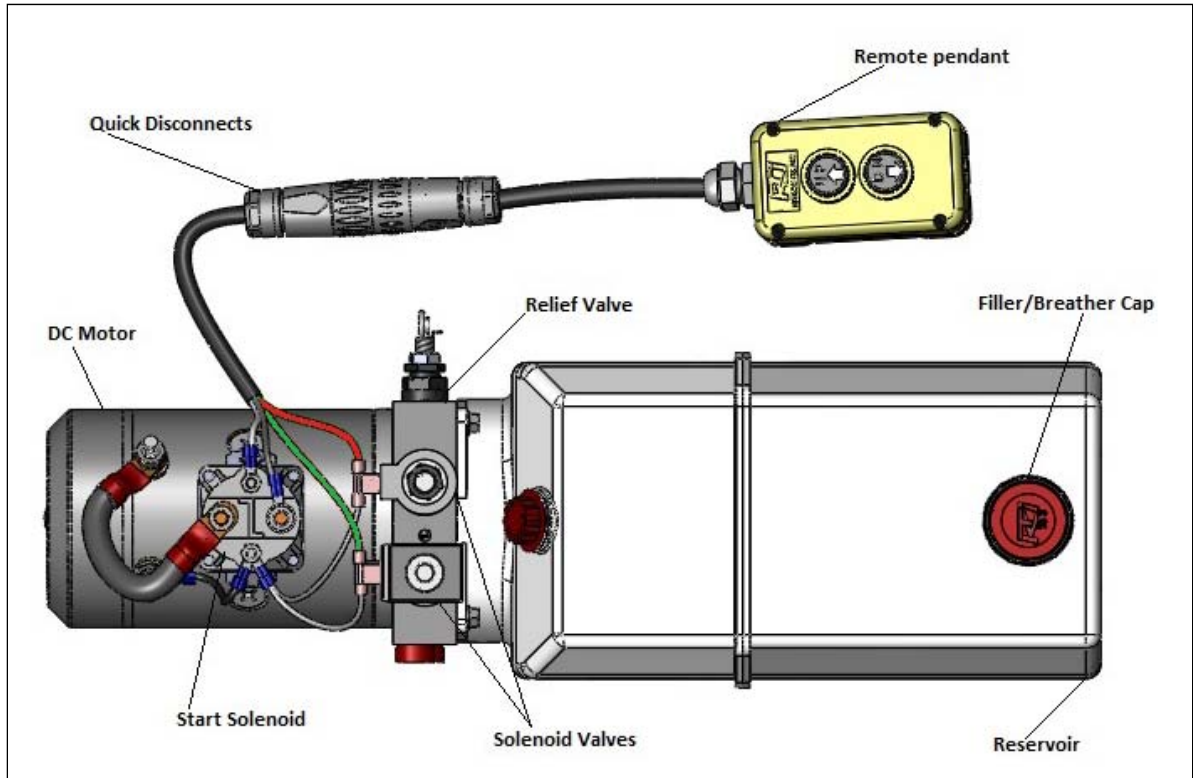

Diagram A-1

1. Install 9/16-18 SAE ORB, SAE #6, hydraulic fittings into ports "A" and "B". Torque fittings to 18 lb-ft.
2. Remove the two-button pendant from the power unit at the quick disconnect.
3. Mount the Power Unit using two, 3/8-16 UNC mounting bolts (*diagram A-3*)
4. Remove the Filler/Breather Cap and fill the reservoir with hydraulic oil (*see fluid recommendations*). Replace the filler/breather cap.
5. Connect Hydraulic Lines to ports "A" (TOP) & "B" (BOTTOM).
 - a. Check the torque specifications for the hose fittings.
 - b. Connect the Base of the Cylinder to the port "A" (TOP).
 - c. Connect the Rod End of the Cylinder to port "B" (BOTTOM).
6. Connect the battery **Ground** cable to the **Ground** terminal of the DC Motor (*diagram A-3*)
7. Connect the **Positive** cable from the battery to the start solenoid (*diagram A-4*).
(See Battery Cable Gauge table for proper gauge for your length of cables.)
8. Holding the bottom nut with a wrench, torque the battery connections to 3 lb-ft.
9. Reconnect the two-button remote pendant at the quick disconnect.
10. Operate the power unit while also keeping an eye on the fluid level in the reservoir.
 - a. Insure that the fluid level doesn't go lower than ½ full during the initial start up.
 - b. When the cylinder is fully extended, the reservoir should be about ½ full.
(The Reason for Not Filling the Reservoir all the way is that during retraction of the cylinder the Butt End of the Cylinder Will Displace Fluid, Causing the Reservoir to Overflow)
11. Run the cylinder Up and Down until all the air is removed from the hydraulic oil.
12. Fill the reservoir to the Full line on Reservoir Label. [Approx. one (1) inch from the top].

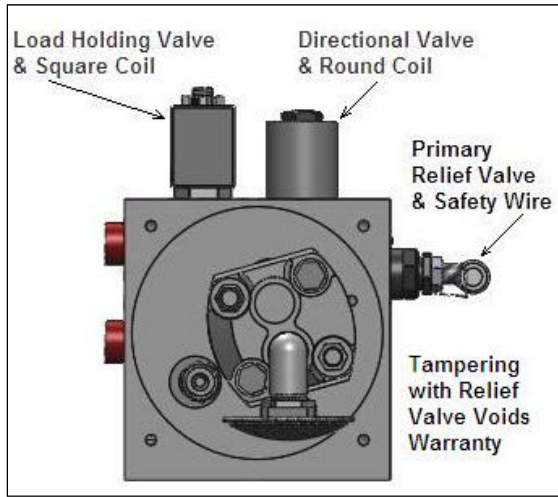

Diagram A-2

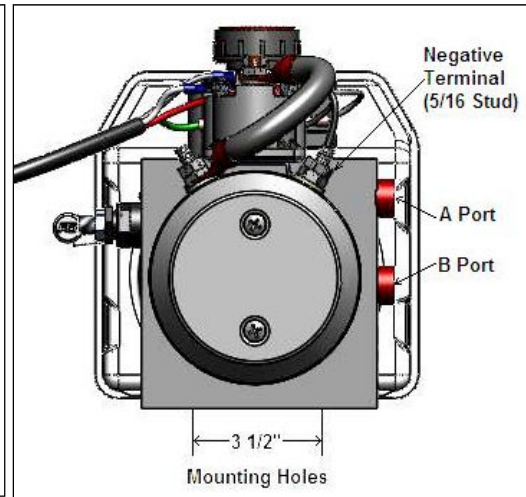

Diagram A-3

Fluid Recommendations

KTI recommends using a premium hydraulic oil to ensure optimum performance and system life. Select oil that has anti-wear properties, rust and oxidation inhibitors, foam inhibitors and good stability. Examples of premium grade hydraulic oils: Chevron Rando HDZ, Mobil DTE 10, DTE 20 series, AMSOIL, and Shell Tellus.

Automotive Transmission Oils are acceptable under normal conditions.

Aviation Oils such as Valvoline ROYCO series or Mobil Aero HF or HFA may be used in **prolonged, extreme cold** environments.

Do Not Use Biodegradable Hydraulic Fluid. Do Not Mix Oils.

Ambient Temperature Range

- 20°F to + 32°F
 (- 29°C to + 0°C)

+ 14°F to + 120°F
 (- 10°C to + 49°C)

ISO Viscosity Grade

15

22, 32, ATF

Battery Cables

To minimize voltage drop, increase the gauge size of the battery cables as the length of the positive and ground cables increase. Low voltage will cause the motor to run at higher amps and may cause damage to other electrical components.

Cable Length	Wire Gauge	Nominal OD (in.)
1 to 2 feet	4 gauge	0.43
3 to 4 feet	2 gauge	0.49
5 to 7 feet	1 gauge	0.56
8 to 9 feet	1/0 gauge	0.61
10 to 12 feet	2/0 gauge	0.66
13 to 15 feet	3/0 gauge	0.72
16 to 19 feet	4/0 gauge	0.78

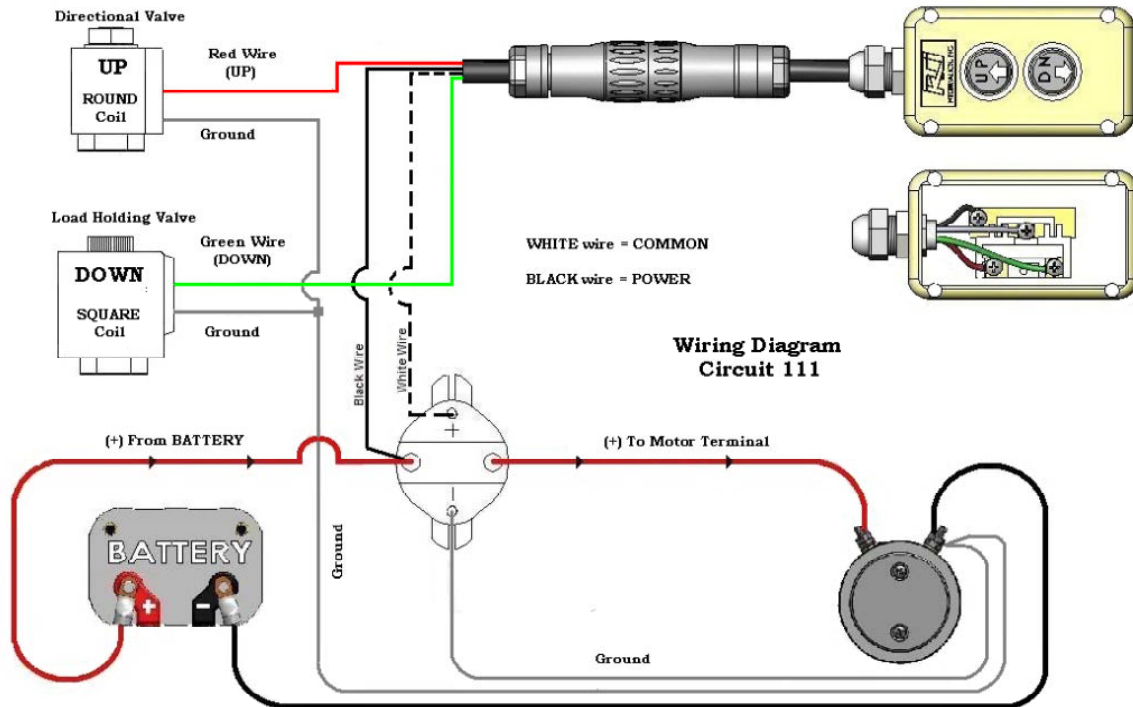
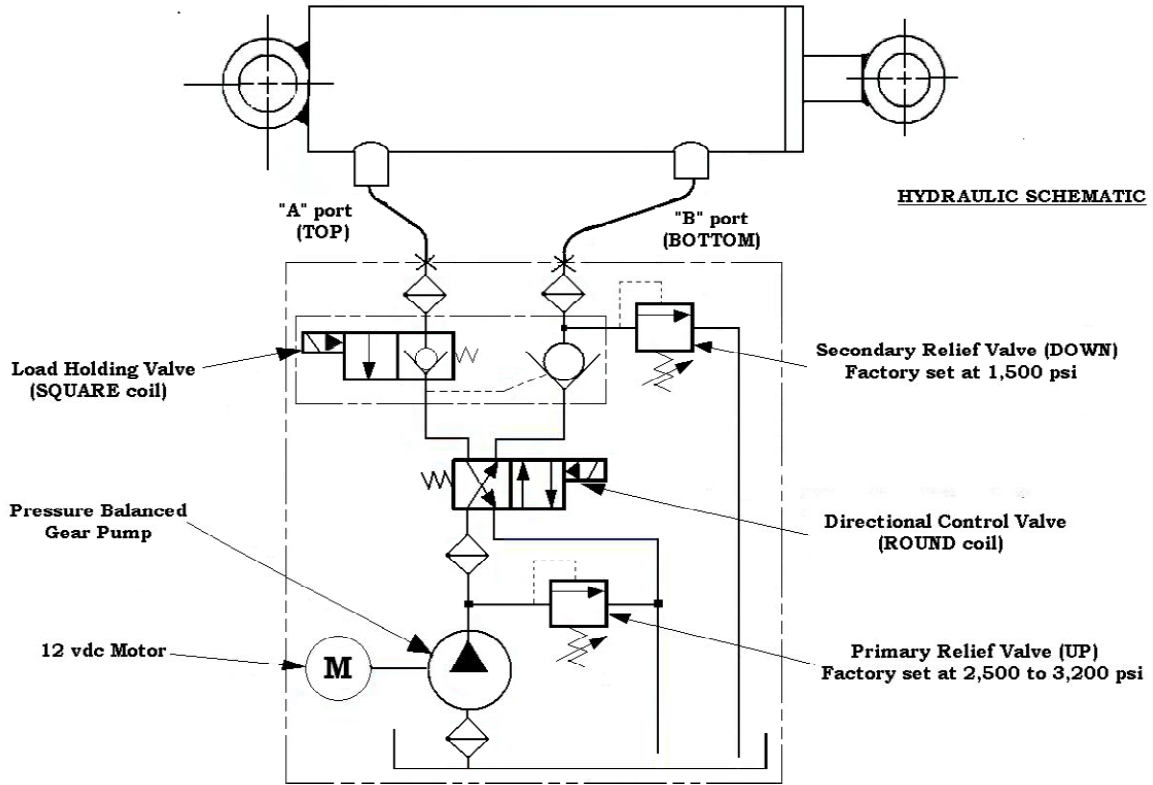

Diagram A-4

Form SVC006

June 2012

Bob Ernst

Digitally signed by Bob Ernst
 DN: cn=Bob Ernst, o=KTI Hydraulics, Inc., email=rob@ktihydraulicsinc.com, c=US
 Date: 2012.06.14 10:46:49 -0700